

Wireless and Multimedia Networking (WiMuNet) Laboratory

Jorge Navarro-Ortiz, Pablo Ameigeiras, Juan J. Ramos-Muñoz,
Jonathan Prados-Garzon, Juan M. Lopez-Soler
Dpt. of Signal Theory, Telematics, and Communications,
ETSI Informática y de Telecomunicación
Universidad de Granada (Spain)
{jorgenavarr, pameigeiras, jjramos, jpg, juanma}@ugr.es

Abstract- This paper reviews the research group *Wireless and Multimedia Networking Lab*, which is formed by faculty and researchers of the Department of Signal Theory, Telematics and Communications of the University of Granada. Its research lines include *broadband wireless networks, video streaming and multimedia traffic analysis, Software Defined Networking, Quality of Experience, Wireless Local Area Networks and Data Distribution Service*. Our latest research projects are focused in 5G mobile communication architectures based on Software Defined Networking and Quality of Experience for multimedia services. Teaching activities of the group members as well as a short bios are also included.

Palabras Clave- WiMuNet, 5G, wireless, multimedia, SDN, DDS.

I. INTRODUCTION

This paper presents the Wireless and Multimedia Networking (WiMuNet) Lab [1] of the University of Granada. It summarizes our activities and achievements in research and training.

WiMuNet is a research team recognized and partially financed by the Andalusian Scientific Information System [2], with identification label TIC-235. It was born in year 2012 as a split from the former Research Group in Signals, Telematics and Communications (TIC-123), founded in 1990. Headed by Prof. Lopez-Soler, WiMuNet members are currently faculty and Ph.D. students from the Higher Technical School of Computer Science and Telecommunications Engineering of the University of Granada, in the area of Telematics Engineering at the Dpt. of Signal Theory, Telematics and Communications. Some of WiMuNet members accumulate past professional experience working in leading companies as Nokia Networks, Optimi and Siemens.

To provide an overall overview of WiMuNet, the rest of the paper is organized as follows. Section II presents the main research lines of the group. Section III summarizes the latest research projects and contracts, whereas Section IV details our teaching activities. Sections V-VIII includes the awards, Ph.D. thesis, patents and short bios of the WiMuNet members. Section IX concludes the paper.

II. RESEARCH LINES

This section presents the main research lines of the WiMuNet Lab.

A. Broadband wireless networks

The area of broadband wireless communication networks is devoted to research and design of 4G (namely, LTE and LTE-Advanced) and 5G mobile networks. Its core objective includes the research of coverage improvements and capacity enhancement solutions that are essential for broadband wireless networks in order to deliver cost-efficient wireless services. Additionally, we investigate the satisfaction of future mobile communication networks requirements through the adoption of an SDN-based design of a hierarchical architecture for the 5G packet core.

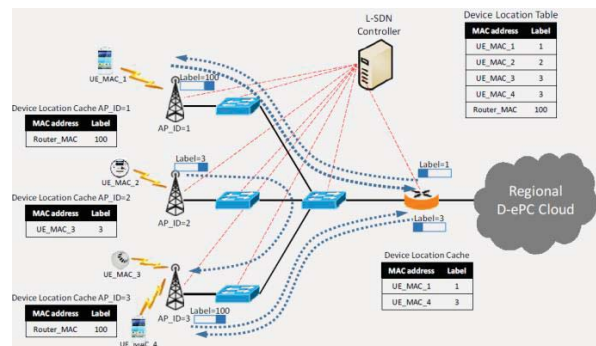

Fig. 1. 5G Access Cloud Architecture.

5G packet core design- The future data traffic load estimations forecast x1000 bandwidth increase in wireless networks by 2020. It will be caused by enriched and augmented new applications in smartphones, as well as massive deployments involving huge number of smart devices using Machine Type Communications (MTC). This disruptive demand is considered a major challenge for future mobile networks. Analysis of this traffic increase reveals new types of applications with extremely challenging requirements, such as vehicular communications or medical applications. The challenges that future 5G systems must address can be summarized as: 1) system capacity and data rate x1000, 2) massive number of connections due to MTC, 3) “zero-perceived” latency, 4) CAPEX and OPEX cost reductions, and 5) quality of experience optimization depending on the type of application. In this context, WiMunet has proposed (Fig. 1) [3][4] the design of an

Access Cloud architecture based on the SDN paradigm with the aim of fulfilling two main link-level challenges: mobility support and network scalability.

Small cells deployment in TV White Spaces– The operation of small cells in TV white spaces represents a coexistence challenge due to their unplanned deployment, their heterogeneous transmission technologies, and the scarcity of TVWS channels in crowded cities. We have designed [5] a centralized game-theoretical solution based on the IEEE 802.19.1 system that maximizes the average network capacity and simultaneously minimize the number of reconfigurations in neighbor cells when a new cell is turned on, based on the *neighborhood* concept (Fig. 2).

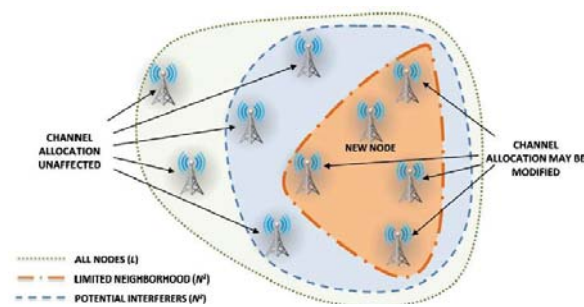

Fig. 2. Channel allocation on a limited neighborhood.

Traffic Models in OFDMA– Our research also studied the impact on the design of scheduling algorithms for Orthogonal Frequency Division Multiple Access (OFDMA) systems of two traffic models: the full buffer and the finite buffer traffic models. In [6] the analysis concentrates on utility-based scheduling with an α -fair utility function for Non-Real Time (NRT) services. Our results show (Fig. 3) that a gradient scheduling algorithm is able to maximize the aggregate utility over all the users when the less realistic full buffer model is adopted; but not when the finite buffer model is applied.

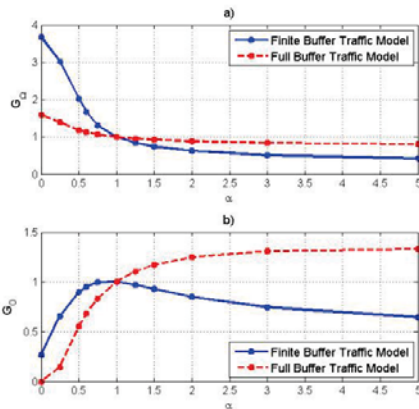

Fig. 3. Finite and full buffer traffic models comparison. (a) Average user throughput gain over Proportional Fair G_α . (b) User throughput at 5% outage gain over Proportional Fair G_0 for different α values.

Packet scheduling for OFDMA-based networks– In this case, our research focuses on the performance evaluation (in

terms of cell throughput and coverage) and design of packet scheduling algorithms (Fig. 4) in OFDMA-based systems by means of network-level Montecarlo simulations. Evaluation is carried out under different degrees of fairness, traffic models, QoS requirements, or propagation conditions [7][8].

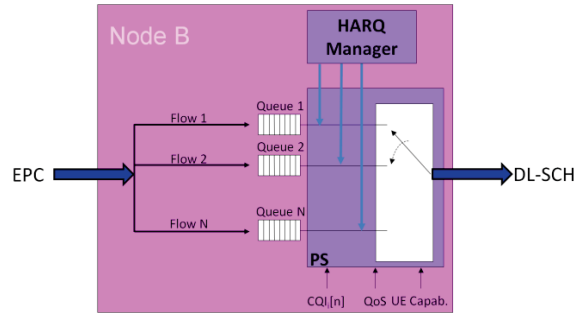

Fig. 4. Packet scheduling for OFDMA-based networks.

B. Video streaming and multimedia traffic analysis

Although we have several contributions related to multimedia services, such as e.g. automatic protocol selection [9], low-latency packet inter-leaver for VoIP using active networks [10-11], or service enhancements using active queue management [12], our most remarkable contributions in this field are related to the analysis of traffic patterns from YouTube servers (Fig. 5). In particular, we have provided traffic models when the video is downloaded from a computer [13] or to a mobile [14] (iOS and Android) device.

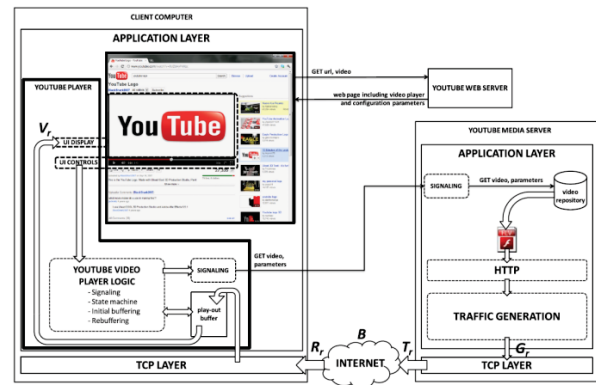

Fig. 5. Overview of the operation of the YouTube service.

In addition, we have proposed a simple model for predicting the number of rebuffering events and their duration in progressive downloads from YouTube. These metrics are necessary to predict the quality perceived by YouTube users. The proposed model can be easily implemented in simulation tools. In [15] we present an example of its use in a Long-Term Evolution simulator.

We also studied the performance of the YouTube service over 3G Long Term Evolution (LTE). We considered a typical configuration of an LTE network for TCP traffic and the traffic generation model for YouTube ‘Flash’ videos downloaded onto a personal computer (PC). The results obtained show that: the number of pauses experimented by users during video download are heavily influenced by the

cell load, but the same is not true for pause duration; most of the packet losses occur during initial burst due to the TCP adaptation to the BDP of the link, and, unlike packet losses during throttling phase, these are not depend on radio link quality; and in most cases the user do not use the maximum data rate achievable in the LTE interface [16].

C. Software Defined Networking

The Information and Communication Technologies (ICT) industry is witnessing a radical paradigm shift with the commoditization of hardware resources and the adoption of cloud computing. In the computer networking field, Software Defined Networking (SDN) and Network Function Virtualization (NFV) are achieving significant success. In particular, both SDN and NFV are expected to play a relevant role in 5G networks [3].

Design and evaluation of OpenFlow services for the provision of QoE– Although SDN is been embraced to provide great flexibility at low expenses, at this moment it has not standardized QoS support. However, SDN allows the development of agile and dynamic services which could benefit the overall QoE assessment of the multimedia services in a network.

To validate this thesis, we are designing and implementing a service which creates QoS-aware routes as part of the OpenDayLight controller. To that end, the controller uses the payload type of a RTP (Real-Time Protocol [18]) flow, calculates an optimal route based on de delay, bandwidth and packet loss rate requirements of the type of content (video streaming or voice over IP). When the network topology changes, the routes for the active flows are updated.

Additionally, we are designing and evaluating several schemes for providing QoS and quality of experience (QoE) to several popular multimedia services in SDN networks, while maintaining the compatibility with legacy (nowadays) networks. To this end, we will define network elements (that will be referred to as middleboxes hereafter) which can be integrated into present and SDN networks.

D. Quality of Experience

Emergent multimedia applications and services, such as VoIP, audio and video streaming, etc., have to face the impairments that IP networks impose (jitter, unbound end-to-end delays, consecutive packet losses, etc.). These impairments can degrade rapidly the quality of the aforementioned services, even making them unusable. Therefore, mitigating the impact of the network impediments and the measurement of such impact, is a must in IP networks.

From the point of view of the network service provider, one of the most important measures of the service performance is the final user satisfaction level. The modeling of the Quality of user Experience (QoE) implies the mapping of objective metrics (such as network impairments, signal degradation or service performance) into an opinion score. These models, tailored for each class of service, may serve to assess the QoE of a service performance in an automatic way. Moreover, using the QoE models as utility functions, we can devise automatic adaptive algorithms to control protocols

selection, resource management or reparation schemes operation.

Utility function for web browsing– After conducting a number of web browsing surveys, we have derived a utility function (Fig. 6) which maps the whole page download time to the user satisfaction (*mean opinion score*) [19].

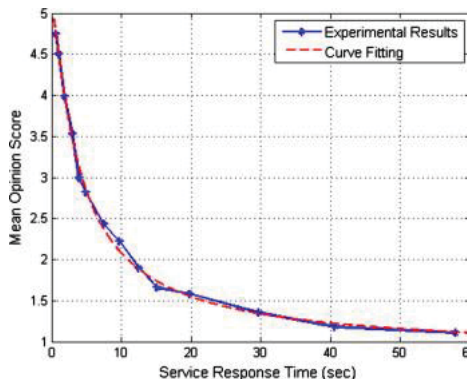

Fig. 6. MOS Vs download time for web browsing.

Utility function for YouTube– Based on surveys, we have derived a utility function which maps the number and duration of playback interruptions (buffer stalls) to the user satisfaction.

QoE-based packet scheduling for LTE and WLAN networks– Based on derived utility functions (and others from the literature), we have designed several mechanisms and algorithms to optimize the end-users perception, especially for LTE [7][8][19] and IEEE 802.11 networks [20][21].

Lightweight Autonomous resilient Networks (LAIN)– LAIN is a proof of concept that a network can select the most promising protocol automatically given dynamic network conditions, by means of probing a set of protocols with provides the same service, and evaluating their performance for each instant. To get this architecture to work, the proper utility functions should be provided to guide the protocol selection [9].

E. Wireless Local Area Networks

We have active research in the field of Wireless Local Area Networks, focusing on quality of service (QoS) and experience (QoE) mechanisms, both in low layers (especially in the MAC layer) and high layers (optimization of TCP/IP protocols and crosslayer procedures) .

QoE-based radio resource management for the IEEE 802.11e HCCA mechanism– The standard allows the developer to select the packet scheduler that best fit his purposes as long as some service requirements are fulfilled. Based on the Monolithic Shaper-Scheduler, we have proposed a method that modifies the resources granted for each traffic class (Fig. 7) according to operator-defined policies, e.g. to maintain certain required levels of Quality of

Experience, to achieve user fairness or to optimize operator's revenue [20][21].

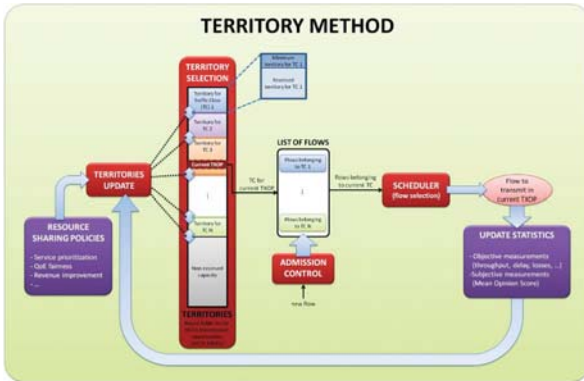

Fig. 7. Territory Method diagram.

TCP enhancement for WLAN– Based on the HCCA mechanism, we have developed [22] a TCP flavor, *Split TCP and UDP* (STU) (Fig. 8), which avoids unfairness between uplink and downlink traffic while improving the end-user performance.

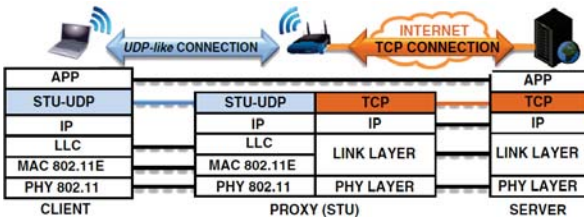

Fig. 8. STU in a wired-cum-wireless network.

F. Data Distribution Service

The Data Distribution Service (DDS) is an OMG standard for data-centric publish-subscribe (DCPS) communication systems. Our research in this field is focused in improving some aspects of the DDS middleware such as discovery, scalability, cloud monitoring, and the use of this technology for real-time multimedia streaming. Our laboratory is partner of Real-Time Innovations Inc., which is “the most influential industrial Internet of Things company” [23]. We are also members of the RTI Research Community.

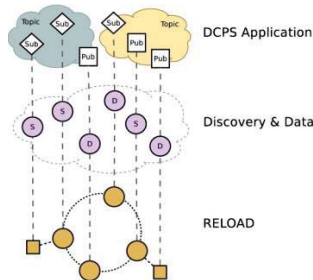

Fig. 9. RELOAD-based Discovery for DCPS.

DDS discovery– In DCPS, prior to sharing data, publishers and subscribers must discover each other (i.e., a rendezvous function is needed). For doing that, among others, a scalable solution is to distribute the discovery information among the members by using a P2P overlay. One of these solutions is REsource LOcation And Discovery (RELOAD), an IETF specification for building and maintaining P2P systems on the Internet. We propose a scalable RELOAD-based solution (Fig. 9) to the discovery problem in DCPS environments [24]. Our proposal demonstrates the extensibility of RELOAD by proposing a RELOAD usage that adapts it for performing rendezvous in DCPS-based deployments.

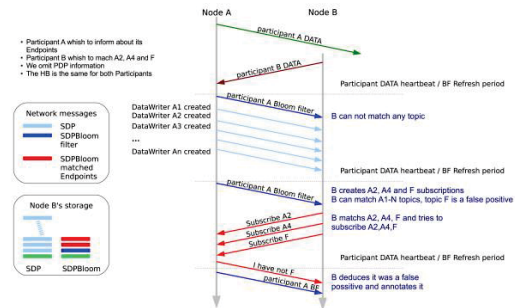

Fig. 10. SDPBloom for DDS Discovery.

To provide interoperability and transparency between different DDS implementations, any compliant DDS implementation must support at least the SDP (Simple Discovery Protocol). We have designed and evaluate SDPBloom, an SDP alternative –which uses Bloom Filters (BF)– (Fig. 10) that increases DDS scalability [25].

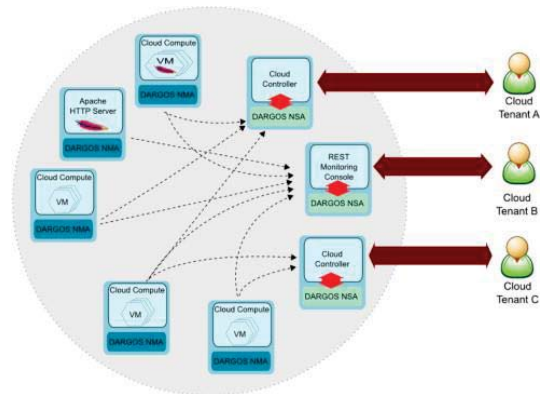

Fig. 11. DARGOS.

DDS for cloud monitoring– One of the most important features in Cloud environments is to know the status and the availability of the physical resources and services present in the current infrastructure. We have proposed [26][27] a Distributed Architecture for Resource management and mOnitoring in cloudS (DARGOS) (Fig. 11), a completely distributed and highly efficient Cloud monitoring architecture to disseminate resource monitoring information based in DDS. DARGOS ensures an accurate measurement of physical and virtual resources in the Cloud keeping at the

same time a low overhead. In addition, DARGOS is flexible and adaptable and allows defining and monitoring new metrics easily.

Multimedia over DDS– DDS is a good candidate for multimedia (such as audio and video) content delivery. The rich set of QoS defined by the DDS standard have to be tuned to enable DDS to distribute multimedia data. Our research is aimed to determine the optimal QoS policies settings (Fig. 12) that can improve the multimedia experience in complex scenarios such as reduced bandwidth environments without the need of classical centralized services [28][29].



Fig. 12. DDS data-spaces allow sharing rich multimedia content.

DDS scalability – Initially DDS systems were restricted to a single, isolated, specific Domain, which was usually confined to a LAN and rarely exceeded one thousand computers. To overcome this restriction, we proposed the DDS Routing Service (DDS-RS) [30]. The DDS-RS (Fig. 13) is a generic service capable of transparently bridging DDS Domains as well as adapting among different data schemas. A key benefit of our approach is that the service can interoperate with existing DDS applications, bridging them without requiring them to be modified. We also showed that the impact of the service on the communications performance is well within the acceptable limits of most real-world uses of DDS. DDS-RS was adopted as a product by RTI DDS ConnexT © implementation.

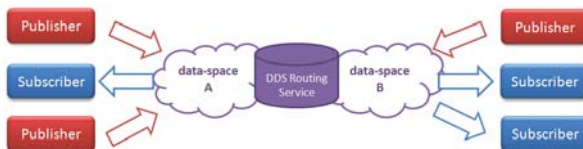

Fig. 13. The DDS-RS transparently bridges DDS domains.

III. LATEST RESEARCH PROJECTS AND CONTRACTS

Our research projects and contracts, both with public and private funding, may be found at [1]. In this section we summarize the latest projects and contracts that are related to our current research.

- Project TIN2013-46223 (subprogram TIN) of the Spanish Ministry of Science and Innovation, titled “Architecture

for 5G mobile communications based on Software Defined Networks,” 2014-2016.

- Project PYR-2014-18 “Virtualization of base stations for 5G mobile communications” of the Granada Excellence Network of Innovation Laboratories (GENIL [31]), 2014.
- Project PYR-2014-20 “Future multimedia networks based on SDN and quality of experience” of GENIL, 2014.
- Project TIN2010-20323 (subprogram TIN) of the Spanish Ministry of Science and Innovation, titled “Radio resource management for 3G Long Term Evolution radio access networks based on Quality of Experience criteria”, 2010-2013.
- Contract “Quality of Experience Enhancements in 3G Long Term Evolution Networks” between the University of Granada and Telefonica I+D, 2011.
- Contract “Framework Agreement Between INDRA Sistemas S.A. and the University of Granada for SESAR Program. Identification of Technology and Services Options & SWIN Prototype” between the University of Granada and INDRA SISTEMAS S.A., 2010-2012.
- Contracts related to DDS with Real-Time Innovations, Inc., 2007 – 2011.

IV. TEACHING

The members of WiMuNet impart the following subjects in the degrees of Telecommunications Engineering and Computer Science Engineering, as well as in their respective masters:

- Degree of Telecommunications Engineering:
 - o Wireless Networks and Mobility (http://dtstc.ugr.es/it/gitt_rim/)
 - o Multimedia Networks (http://dtstc.ugr.es/it/gitt_rm/)
 - o Switching Systems (http://dtstc.ugr.es/it/itt_sc/)
 - o Access and Corporate Networks (http://dtstc.ugr.es/it/gitt_rac/)
 - o Development of Network Applications (http://dtstc.ugr.es/it/gitt_dar/)
 - o Data Transmission and Computer Networks (http://dtstc.ugr.es/it/gitt_tdrc/)
 - o Communications Infrastructures and Networks (http://dtstc.ugr.es/it/itt_irc/)
 - o Telematics Laboratory (http://dtstc.ugr.es/it/gitt_lt/)
- Degree of Computer Science Engineering:
 - o Networking Fundamentals (http://dtstc.ugr.es/it/gii_fr/)
 - o Multiservice Networks (http://dtstc.ugr.es/it/ii_rm/)
- Master of Telecommunications Engineering:
 - o Advanced Networks and Services (http://dtstc.ugr.es/it/mit_rsa/)

o Internet Technologies and Distributed Systems

- Master of Computer Science Engineering:
 - o Computer Science Projects Planning and Management (http://dtstc.ugr.es/it/mii_pgpi/)

V. PH.D. THESIS

The following are the Ph.D. thesis carried out at the WiMuNet Lab or by WiMuNet members:

- Jonatan Prados-Garzon: “Architecture for 5G Mobile Networks based on SDN (*Software-Defined Networking*),” under development. Supervised by Prof. Lopez-Soler.
- Javier Povedano-Molina, “A data-centric publish/subscribe approach for multimedia service provisioning,” 2013. Supervised by Prof. Lopez-Soler. Available at <http://hera.ugr.es/tesisugr/2249330x.pdf>
- Jose M. Lopez-Vega, “Discovery and signaling enhancements for data-centric publish-subscribe environments,” 2013. Supervised by Prof. Lopez-Soler and Dr. Pardo-Castellote. Available at <http://hera.ugr.es/tesisugr/2220037x.pdf>
- Jorge Navarro-Ortiz, “Mechanisms for improving the Quality of Experience over IEEE 802.11 networks,” 2010. Supervised by Prof. Lopez-Soler. Available at <http://hera.ugr.es/tesisugr/18858764.pdf>
- Erika P. Alvarez-Flores, “Selective packet dropping in active queue management mechanisms,” 2009. Supervised by Prof. Lopez-Soler. Available at <http://hera.ugr.es/tesisugr/17983824.pdf>
- Juan J. Ramos-Munoz, “Improvements for voice transmission over IP considering experienced quality criteria,” 2009. Supervised by Prof. Lopez-Soler. Available at <http://hera.ugr.es/tesisugr/17891875.pdf>
- Pablo Ameigeiras, “Packet scheduling and Quality of Service in HSDPA,” 2003. Supervised by Prof. Preben E. Mogensen and Ph.D. Jeroen Wigard. Available at http://vbn.aau.dk/files/14366040/pablo-phdthesis_day28032004_time2300-2.pdf
- Juan M. Lopez-Soler, “Aproximación experimental al mejor compromiso R-D para la codificación de la voz a muy bajo bit-rate”, 1995. Supervised by Prof. Antonio Rubio Ayuso.

VI. AWARDS

Awards granted to WiMuNet members are included next:

- Certificate of the Higher Technical School of Computer Science and Telecommunications Engineering to 4 members of the team recognizing the excellence of their research.
- IEEE article of the month (April 2014) [14].

- Best Paper 2013 of the Transactions on Emerging Telecommunications Technologies journal with the paper [13].
- Paper [13] selected as one of the top articles published on the Transactions on Emerging Telecommunications Technologies journal of 2013 (Editor’s Pick 2013).
- M.Sc. thesis “Integration scenarios for satellite and terrestrial LTE networks for seamless video delivery,” realized by Mr. Ramon Gigante Carrizosa and directed by Dr. Ameigeiras. First position in the 1st edition of M.Sc. thesis awards of the Dpt. of Signal Theory, Telematics and Communications of the University of Granada.
- M.Sc. thesis “Performance evaluation of MIMO schemes in closed-loop for wireless networks: signaling and link adaptation,” realized by Mr. Juan Jose Lopez Villar and supervised by Dr. Ameigeiras and Jonathan Prados Garzon. Second position (shared) in the 1st edition of M.Sc. thesis awards of the Dpt. of Signal Theory, Telematics and Communications of the University of Granada.
- M.Sc. thesis “Performance evaluation of MIMO schemes in closed-loop for wireless networks: channel and receptor modelling,” realized by Mrs. Alba Maria Rivera Perez and supervised by Dr. Ameigeiras and Jonathan Prados Garzon. Second position (shared) in the 1st edition of M.Sc. thesis awards of the Dpt. of Signal Theory, Telematics and Communications of the University of Granada.
- M.Sc. thesis “Femtocell deployment in multioperator environments over TV White Spaces,” realized by Ms. Ana Maria Lopez Perez and supervised by Dr. Navarro-Ortiz. First position in the 2nd edition of M.Sc. thesis awards of the Dpt. of Signal Theory, Telematics and Communications of the University of Granada.
- M.Sc. thesis “Video tester,” realized by Mr. Inaki Ucar Marques and supervised by Prof. Lopez-Soler and Dr. Navarro-Ortiz. Finalist of the ONO award given by the Spanish Official Association of Telecommunications Engineers. “Highly Commended Award” in the category of M.Sc. Thesis with Best Business Perspectives in ICT from the Higher Technical School of Computer Science and Telecommunications Engineering of the University of Granada.
- M.Sc. thesis “YouTube mobile traffic modeling,” realized by Hector A. Aguilera-Garcia and directed by Dr. Ramos-Munoz. Secondary award in the category of M.Sc. Thesis with Best Business Perspectives in the ICT industries from the ETSIIT.
- Juan J. Ramos-Munoz was awarded with the “Premio extraordinario de fin de carrera,” prize awarded to the most outstanding graduate in the Computer Science degree, University of Granada, 2001.

- Juan J. Ramos-Munoz was awarded with the “Premio extraordinario de fin de carrera,” in the Computer Systems degree, University of Granada, 1999.

VII. PATENTS

The members of the team hold the following patents:

- P. Ameigeiras, J. Navarro-Ortiz, J.M. Lopez-Soler, R. Garcia-Perez, Q. Perez-Tarrero, J. Lorca-Hernando, “A method and a system for scheduling the downlink in Long Term Evolution (LTE) networks based on Quality of Service (QoS),” applicant Telefonica S.A., spanish patent ES2429663 A2, international patent PCT/EP2013/053324, 2013.
- P. Ameigeiras, E. Sillasto, J. Wigard, “Adaptive delayed ACK switching for TCP applications,” applicant Nokia Corporation, US Patent 7,225,266 B2, 2007.
- P. Ameigeiras, J. Wigard, “Method, system and transmitting side protocol entity for sending packet data units for unacknowledged mode services,” applicant Nokia Corporation, international patent PCT/FI2004/000700, 2005.
- J. Wigard, T. Kolding, P. Mogensen, P. Ameigeiras, W. Hwang, H. Hakkinen, “Scheduling retransmission in Radio Access Networks,” applicant Nokia Corporation, international patent PCT/IB2003/005716, 2004.
- A. Töllli, J. Navarro-Ortiz, H. Montes-Linares, “A Traffic Management Method that Divides Time Slots into Sub-Blocks for Real Time and Non-Real Time Traffic,” applicant Nokia Corporation, international patent PCT/FI2004/000285, 2004.
- P. Ameigeiras, E. Sillasto, J. Wigard, “Method and system for dispatching multiple TCP packets from communication systems,” applicant Nokia Corporation, international patent PCT/FI2001/001054, 2003.

VIII. PEOPLE

This section includes a summary of the curriculum vitae of the members of WiMuNet.

A. Juan M. Lopez-Soler



Juan M. Lopez-Soler is Full Professor at the Department of Signals, Telematics and Communications of the University of Granada (Spain). He teaches undergraduate and graduate courses in Computer Networks, Data Transmission, and Multimedia Networking. He received the B.S. degree in Physics (Electronics). In 1991-92, he joined the Institute for Systems Research (formerly SRC) at the University of Maryland (USA) as Visiting Faculty Research Assistant. In 1995 he received the Ph.D. degree from the University of Granada. He has participated in more than 15 public and private funded research projects, being the coordinator in 7 of them. He has published more than 50 papers in international conferences and journals. His research

interests include wired and wireless multimedia networking and real-time middleware.

B. Pablo Ameigeiras



Pablo Ameigeiras received his M.Sc.E.E. degree in 1999 by the University of Malaga, Spain. He carried his Master Thesis at the Chair of Communication Networks, Aachen University (Germany). In 2000, he joined the Cellular System group at the Aalborg University (Denmark) where he carried out his Ph.D. thesis. After finishing his Ph.D., Pablo worked in Optimi (now Ericsson). In 2006, he joined the Department of Signal Theory, Telematics, and Communications at the University of Granada (Spain). Since then, he has been leading several projects in the field of LTE and LTE-Advanced systems. Currently, his research interests include 4G and 5G wireless systems.

C. Jorge Navarro-Ortiz



Jorge Navarro Ortiz is Associate Professor (*Profesor Contratado Doctor*) at the Department of Signal Theory, Telematics and Communications of the University of Granada. He obtained his M.Sc. in Telecommunications Engineering by the University of Malaga (Spain) in 2001. Afterwards, his professional career was developed in the mobile communications field, working at Nokia Networks, Optimi (acquired by Ericsson) and Siemens. He started working at the University of Granada in 2006, where he got a Ph.D. in Telecommunications Engineering with the thesis titled “Mechanisms for Improving the Quality of Experience over IEEE 802.11 Networks”, realized under the supervision of Prof. Lopez-Soler. During this work, he performed a research stay at the *Dipartimento di Ingegneria dell’Informazione* of the University of Pisa in summer 2009. During summer 2012 he was a visiting researcher with the Broadband Wireless Networking Lab of the School of Electrical and Computer Engineering of the Georgia Institute of Technology. His research interests include cognitive radio, heterogeneous networks, 4G and 5G wireless systems among others.

D. Juan J. Ramos-Munoz



Juan J. Ramos-Munoz received his M.Sc. in Computer Sciences in 2001 by UGR (University of Granada, Spain). Since 2009 he holds a doctorate degree from UGR. He is a lecturer in the Department of Signals Theory, Telematics and Communications of UGR. He is also member of the Wireless and Multimedia Networking Lab. His research interests are focused on software defined networks, and 5G, real-time multimedia streaming, quality of experience (QoE) assessment, Distributed Data Service (DDS), and adaptive mechanisms for providing QoS to Real-Time multimedia flows.

E. Jonathan Prados-Garzon



Jonathan Prados-Garzon received his MSc. in Telecommunications Engineering by the University of Granada (Spain) in 2011. He was granted a FPU fellowship by the Spanish Ministry of Education on 2014 and started his Ph.D. studies at the Department of Signal Theory, Telematics and Communication of the University of Granada. His research interests are focused on Quality of Experience (QoE) and 3G LTE systems.

IX. CONCLUSIONS

This paper summarizes our main research and teaching activities, and presents the members of the WiMuNet Lab of the University of Granada.

ACKNOWLEDGMENTS

This work is supported by the Spanish Ministry of Science and Innovation (project TIN2013-46223).

REFERENCES

[1] WiMuNet web page, available at <http://wimunet.ugr.es> (old version available at <http://dstc.ugr.es/tl/home.html>).

[2] Andalusian Scientific Information System (SICA), available at <https://sica2.cica.es/>.

[3] P. Ameigeiras, J.J. Ramos-Munoz, J. Prados-Garzon, J. Navarro-Ortiz, J.M. Lopez-Soler, "Link-level Access Cloud architecture design based on SDN for 5G Networks," *IEEE Network*, vol. 29, issue 2, pp. 24-31, March 2015.

[4] A.F. Cattoni, P.E. Mogensen, S. Vesterinen, M. Laitila, L. Schumacher, P. Ameigeiras, J.J. Ramos-Munoz, "Ethernet-based mobility architecture for 5G," *IEEE 3rd International Conference on Cloud Networking (CloudNet 2014)*, pp. 449-454, 2014.

[5] P. Ameigeiras, D.M. Gutierrez-Estevez, J. Navarro-Ortiz, "Dynamic deployment of small cells in TV White Spaces," *IEEE Transactions on Vehicular Technology*, issue 99, October 2014.

[6] P. Ameigeiras, Y. Wang, J. Navarro-Ortiz, P.E. Mogensen, J.M. Lopez-Soler, "Traffic models impact on OFDMA scheduling design," *Eurasip Journal on Wireless Communications and Networking*, 2012.

[7] P. Ameigeiras, J.J. Ramos-Munoz, J. Navarro-Ortiz, J. Ramiro-Moreno, J.M. Lopez-Soler, "QoE evaluation of scheduling algorithms for NRT services in LTE," *ICT-MobileSummit 2009, Santander (Spain)*, June 2009.

[8] P. Ameigeiras, J.J. Ramos-Munoz, J. Navarro-Ortiz, P. Mogensen, J.M. Lopez-Soler, "QoE oriented cross-layer design of a resource allocation algorithm in Beyond 3G systems," *Computer Communications*, March 2010.

[9] J.J. Ramos-Muñoz, L. Yamamoto, C. Tschudin, "Serial experiments online," *Computer Communication Review*, vol. 38, 2, pp. 31-42, 2008.

[10] J.J. Ramos-Muñoz, A.M. Gomez-Garcia, J.M. Lopez-Soler, "Intelligibility evaluation of a VoIP multi-flow block interleaver," *Lecture Notes in Computer Science*, pp. 200-205, 2005.

[11] J.J. Ramos-Muñoz, J.M. Lopez-Soler, "Low delay multiframe block interleavers for real-time audio streaming," *Lecture Notes in Computer Science*, vol. 3420, pp. 909-916, 2005.

[12] E.P. Alvarez-Flores, J.J. Ramos-Munoz, P. Ameigeiras, J.M. Lopez-Soler, "Selective packet dropping for VoIP and TCP flows," *Telecommunication Systems*, 46 (1), pp. 1-16, 2011.

[13] P. Ameigeiras, J.J. Ramos-Munoz, J. Navarro-Ortiz, and J.M. Lopez-Soler, "Analysis and modeling of YouTube traffic," *Transactions on Emerging Telecommunications Technologies*, vol. 23, issue 4, pp. 360-377, June 2012.

[14] J.J. Ramos-Munoz, J. Prados-Garzon, P. Ameigeiras, J. Navarro-Ortiz, J.M. Lopez-Soler, "Characteristics of mobile YouTube," *IEEE Wireless Communications Magazine*, special issue on Mobile Social Networks, February 2014.

[15] P. Ameigeiras, A. Azcona-Rivas, J. Navarro-Ortiz, J.J. Ramos-Munoz, J.M. Lopez-Soler, "A simple model for predicting the number and duration of rebuffering events for YouTube flows," *IEEE Communications Letters*, vol. 16, issue 2, pp. 278-280, 2012.

[16] J. Prados-Garzon, P. Ameigeiras, J. Navarro-Ortiz, J.M. Lopez-Soler, "Simulation-based performance study of YouTube service in 3G LTE," *IEEE 14th International Symposium on a World of Wireless, Mobile and Multimedia Networks (WoWMoM 2013)*, Madrid (Spain), June 2013.

[17] OpenDayLight, available at <http://www.opendaylight.org/>.

[18] H. Schulzrinne, S. Casner, R. Frederick, V. Jacobson, RFC 3550, "RTP: A Transport Protocol for Real-Time Applications," 2003.

[19] J. Navarro-Ortiz, P. Ameigeiras, J.M. Lopez-Soler, J. Lorca-Hernando, Q. Perez-Tarrero, R. Garcia-Perez, "A QoE-Aware Scheduler for HTTP Progressive Video in OFDMA Systems," *IEEE Communications Letters*, April 2013.

[20] J. Navarro-Ortiz, G. Stea, J.M. Lopez-Soler, "Quality of Experience Based Resource Sharing in IEEE 802.11e HCCA," *European Wireless 2010, Lucca (Italia)*, April 2010.

[21] J. Navarro-Ortiz, P. Ameigeiras, J.J. Ramos-Muñoz, J.M. Lopez-Soler, "An 802.11e HCCA scheduler with an end-to-end quality aware territory method," *Computer Communications*, vol. 32, issue 11, special issue on Heterogeneous Networking for Quality, pp. 1281-1297, 2009.

[22] J. Navarro-Ortiz, P. Ameigeiras, J.J. Ramos-Muñoz, J.M. Lopez-Soler, "Removing redundant TCP functionalities in wired-cum-wireless networks with IEEE 802.11e HCCA support," *International Journal of Communication Systems*, 2013.

[23] Real-Time Innovations Inc., available at <http://www.rti.com>.

[24] J.M. Lopez-Vega, G. Camarillo, J. Povedano-Molina, J.M. Lopez-Soler, "RELOAD extension for data discovery and transfer in data-centric publish subscribe environments," *Computer Standards and Interfaces*, vol. 36, issue 1, pp. 110-121, 2013.

[25] J. Sanchez-Monedero, J. Povedano-Molina, J.M. Lopez-Vega, J.M. Lopez-Soler, "Bloom filter-based discovery protocol for DDS middleware," *Journal of Parallel and Distributed Computing*, vol. 71 (nº 10), pp. 1305-1317, Oct. 2011.

[26] J. Povedano-Molina, J.M. Lopez-Vega, J.M. Lopez-Soler, A. Corradi, L. Foschini, "DARGOS: A highly adaptable and scalable monitoring architecture for multi-tenant clouds," *Future Generation Computer Systems*, vol. 29, issue 8, pp. 2041-2056, Oct. 2013.

[27] A. Corradi, L. Foshini, J. Povedano-Molina, J.M. Lopez-Soler, "DDS-enabled cloud management support for fast task offloading," *17th IEEE Symposium on Computers and Communication, Capadocia (Turkey)*, Jul. 2012.

[28] J. Povedano-Molina, J.M. Lopez-Vega, J.M. Lopez-Soler, "EMDS: an Extensible Multimedia Distribution Service," *Workshop on Real-time, Embedded and Enterprise-Scale Time-Critical Systems*, Arlington, VA (USA), May 2010.

[29] J.M. Lopez-Vega, J. Sanchez-Monedero, J. Povedano-Molina, J.M. Lopez-Soler, "QoS policies for audio/video distribution over DDS," *Workshop on Distributed Object Computing for Real-Time and Embedded Systems*, Arlington, VA (USA), Jul. 2008.

[30] J.M. Lopez-Vega, J. Povedano-Molina, G. Pardo-Castellote, J.M. Lopez-Soler, "A content-aware bridging service for publish/subscribe environments," *Journal of Systems and Software*, vol. 86, issue 1, pp. 108-124, Jan. 2013.

[31] Granada Excellence Network of Innovation Laboratories (GENIL) project, available at <http://genil.ugr.es>.